



June 25, 2001

BOX PCT

Commissioner for Patents
Washington, D.C. 20231

ICT/EP99/10374
-filed December 23, 1999

Re: Application of Ralph BERKE
SYSTEM FOR INJECTING A CONTRAST MEDIUM
Assignee: Guido HILEKES and Ralph BERKE
Our Ref: Q64906

Dear Sir:

Applicant herewith submit the attached papers for purpose of entering the National Stage under 35 U.S.C. § 371 and in accordance with Chapter II of the Patent Cooperation Treaty: an English Translation of the International Application and 1sheet of formal drawing.

It is assumed that copies of the International Application and International Search Report will be supplied directly by the International Bureau, but if further copies are needed, the undersigned can easily provide them upon request.

Assignment for published patent application are Guido HILEKES and Ralph BERKE

A Preliminary Amendment is attached.

The Government filing fee is calculated as follows:

Total claims	<u>40</u> - 20 = <u>20</u>	x \$18.00 =	<u>\$360.00</u>
Independent claims	<u>3</u> - 3 = <u>0</u>	x \$80.00 =	<u>\$0.00</u>
Base Fee			<u>\$860.00</u>
Multiple Dependent Claim Fee			<u>\$270.00</u>

TOTAL FEE \$1490.00

Please charge the deposit account for the statutory filing fee of \$1490.00. You are also directed and authorized to charge or credit any difference or overpayment to Deposit Account No. 19-4880. The Commissioner is hereby authorized to charge any fees under 37 C.F.R. §§ 1.16, 1.17 and 1.492 which may be required during the entire pendency of the application to Deposit Account No. 19-4880. A duplicate copy of this transmittal letter is attached.

Priority is claimed from December 23, 1998 based on DE Application No. 198 59 811.4.

Respectfully submitted,

Alan J. Kasper
Registration No. 25,426

SUGHRUE, MION, ZINN,
MACPEAK & SEAS, PLLC
2100 Pennsylvania Avenue, N.W.
Washington, D.C. 20037-3213
Telephone: (202) 293-7060
Facsimile: (202) 293-7860

Date: June 25, 2001

FOOTER " 63063860

IN THE UNITED STATES PATENT AND TRADEMARK OFFICE

In re application of

Ralph BERKE

Appln. No.: UNKNOWN

Group Art Unit: UNKNOWN

Confirmation No.: UNKNOWN

Examiner: UNKNOWN

Filed: June 25, 2001

For: SYSTEM FOR INJECTING A CONTRAST MEDIUM

PRELIMINARY AMENDMENT

Commissioner for Patents
Washington, D.C. 20231

Sir:

Prior to examination, please amend the above-identified application as follows:

IN THE CLAIMS:

Please add the following new claims 22-36:

22. (New) Contrast agent injection system for injecting a contrast agent into a body, having at least a first injector (1) for delivering the contrast agent to a tube (9) connected to the body, and having at least a second injector (2) for delivering a rinsing fluid to the tube (9), characterized by a control device (16) being arranged independently from said first injector (1), wherein said control device (16) is connected with its output to said second injector (2) for controlling said second injector (2), that the control device (16) is connected with its input to a sensing device (14), said sensing or detecting device (14) is sensing the fluid flow within a subordinate tube section (7a), said fluid flow being produced by said first injector (1), such that the control device (16) activates the second injector (2) if the sensing device (14) detects an interruption of the fluid flow within the tube section (7a) which is connected to said first injector (1).

23. (New) Contrast agent injection system for injecting a contrast agent into a body, having at least a first injector (1) for delivering the contrast agent to a tube (9) connected to the body, and having at least a second injector (2) for delivering a rinsing fluid to the tube (9), characterised by a control device (16) being arranged independently from said first injector (1), wherein said control device (16) is connected with its output to said second injector (2) for controlling said second injector (2), that the control device (16) is connected with its input to a detection device (20) which detects an optical signal from said first injector (1) as a result of the interruption of the injection of said first injector (1), wherein the first injector (1) comprises a device (18) for producing a status display as an optical signal such that the control device (16) activates the second injector (2) when said detection device (20) detects the interruption of the injection of the fluid flow in the tube section (7a) which is connected to said first injector (1).

24. (New) Contrast agent injection system according to Claim 22 characterised in that the fluid flow sensing device (14) has a light-emitting unit and a light-receiving unit for sensing the light reflection caused by the fluid particles.

25. (New) Contrast agent injection system according to Claim 24 characterised in that the sensing device (14) has a sound-emitting unit and a sound-receiving unit for sensing the sound frequency shift caused by the moving fluid particles.

26. (New) Contrast agent injection system according to claim 22, characterised in that the control device (16) is connected to a contrast agent volume calculating device (24).

27. (New) Contrast agent injection system according to Claim 26 characterised in that the contrast agent volume calculating device (24) has a contrast agent volume memory device in which the contrast agent volume located in the first injector (1) is stored.

28. Contrast agent injection system according to claim 22, characterised in that the control device (16) is connected to a contrast agent injection time calculating device (22).

29. (New) Contrast agent injection system according to Claim 28, characterised in that the contrast agent injection time calculating device (22) has a contrast agent injection time memory device in which the contrast agent injection time is stored.

30. (New) Contrast agent injection system according to claim 22, characterised in that the control device (16) is connected to an input device (26) for inputting the contrast agent volume and the contrast agent injection time.

31. (New) Contrast agent injection system according to claim 22, characterised in that the first injector (1) and the second injector (2) are connected via an adapter (7) to a tube (9) which is connected to the body.

32. (New) Contrast agent injection system according to Claim 31, characterised in that valves (10, 11) are provided for filling the injectors (1, 2).

33. (New) Contrast agent injection system according to Claim 32, characterised in that the valves (10, 11) can be controlled via the control device (16).

34. (New) Contrast agent injection system according to claim 22, characterised in that the injectors (1, 2) are single-piston or multipiston injectors.

35. (New) Contrast agent injection system according to claim 22, characterised in that interchangeable pressure syringes (3, 4) can be held by the injectors (1, 2) in mounting openings (27, 28).

36. (New) Contrast agent injection system according to Claim 35, characterised in that the mounting openings (27, 28) have different mounting openings corresponding to the associated pressure syringes (3, 4).

REMARKS

Entry and consideration of this Amendment is respectfully requested.

Respectfully submitted,

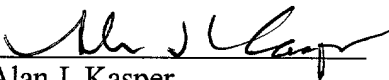

Alan J. Kasper
Registration No. 25,426

SUGHRUE, MION, ZINN,
MACPEAK & SEAS, PLLC
2100 Pennsylvania Avenue, N.W.
Washington, D.C. 20037-3213
Telephone: (202) 293-7060
Facsimile: (202) 293-7860

Date: June 25, 2001

FOR THE "6806880"

09/869059

531 Rec'd PCT

25 JUN 2001

APPENDIX

VERSION WITH MARKINGS TO SHOW CHANGES MADE

IN THE CLAIMS:

Claims 22-36 are added as new claims.

FOR THE "GROSS" FOR

1/PRTS

09/869059

531 Rec'd PCT.

25 JUN 2001

P11961

Contrast agent injection system

5 The invention relates to a contrast agent injection system for injecting a contrast agent into a body according to the preamble of Patent Claim 1.

DE 297 21 247 discloses an injection system for the
10 combined bolus injection of contrast agent and sodium chloride solution. This injection system comprises two machine pressure syringes which are connected to the injection point on a patient's body in a parallel arrangement via a tube system. This permits automatic
15 subsequent injection of a rinsing agent without having to change tube connections or open, close or switch over faucets in order to do so. In a first pressure syringe there is a contrast agent which is fed to the patient's body for diagnostic purposes, while a sodium
20 chloride solution, for example, is provided as rinsing agent in a second pressure syringe. In particular in the field of computer tomography, the patient is injected with a contrast agent in order to show up vascularized tissue in X-ray investigations. So that
25 the patient suffers as little stress as possible due to the quantity of contrast agent which is administered, and in order to reduce the risk of reactions by the body's defence system or complications, the volume of contrast agent which is to be injected is kept as small
30 as possible. Furthermore, cost savings are made by minimizing the amount of relatively expensive contrast agent. However, on the other hand, the volume of contrast agent administered must be sufficiently large to avoid adversely affecting the quality of the
35 diagnostics. The quantity of contrast agent administered must therefore be optimized as a critical factor when the injection is made. Subsequent injection with a rinsing agent, for example a sodium chloride solution, permits the remaining contrast agent located

FOR "SECRET" 110505050

in the tube supplying the patient, and partially also
the volume of contrast agent located in the patient's
vein, to be utilized. The relatively cost-effective
sodium chloride solution rinses out the injection path
5 and thus significantly increases the yield of contrast
agent.

The injection system described in DE 297 21 247 has the
disadvantage that the automatic subsequent injection of
10 the sodium chloride solution is initiated independently
of the quantity of contrast agent actually flowing
through the patient tube. There is thus no control over
the quantity of contrast agent which actually gets into
the patient's body. If only some of the contrast agent
15 delivered by the contrast agent pressure syringe is
supplied to the patient's body because of a faulty
connection of the contrast agent injector to the tube,
for example, a subsequent injection occurs even though
sufficient contrast agent has not yet been fed into the
20 patient's body. This excessively small quantity of
contrast agent leads to a worsening of the quality
during the X-ray diagnosis. Furthermore, the injection
system described in DE 297 21 247 has a safety problem.
If, for example, the engine controller of the machine
25 contrast agent pressure syringe is imprecise or
defective, it is possible, under certain circumstances,
for an excessively large amount of contrast agent to be
emitted into the patient tube without this being sensed
and the inflow of contrast agent being promptly
30 terminated. If excessively high quantities of contrast
agent are supplied to the patient, this can result in
damage to the patient's health.

The object of the present invention is therefore to
35 provide a contrast agent injection system which is safe
for the patient and which monitors the quantity of
contrast agent fed to the patient's body. This object
is achieved according to the invention by means of a

contrast agent injection system having the features specified in Patent Claim 1.

5 Further advantageous refinements are specified in the subclaims.

The invention advantageously provides the possibility of subsequently retrofitting previously used single-piston injectors to form a dual-piston system. In this
10 context it is advantageously possible to actuate the second or additional injector without direct electronic connection to the first injector, i.e. the second injector is activated by the control device without electronic connection to the first injector.

15 A preferred embodiment of the invention will be described below with reference to the appended figure in order to explain the features which are essential to the invention.

20 The figure shows a preferred embodiment of the contrast agent injection system according to the invention.

The contrast agent injection system has a first
25 injector 1 for delivering a contrast agent and a second injector 2 for delivering a rinsing fluid. The injectors shown are single-piston injectors into which interchangeable pressure syringes 3, 4 are inserted. The contrast agent to be injected is located in the
30 pressure syringe 3, and a rinsing fluid, for example a sodium chloride solution, is located in the pressure syringe 4. The two pressure syringes 3, 4 are each connected to an adapter 7 via connections 5, 6. The adapter 7 is connected via a connection 8 to a tube 9
35 and preferably has a Y-shaped structure. The tube 9 is connected to a blood vessel of the patient's body by means of an injection needle, for example. Two non-return valves 10, 11, preferably two double non-return

TELETYPE UNIT

valves 10, 11, are provided in the vicinity of the adapter 7 and/or at the output end of the respective filling unit, represented by the filling tubes 12, 13. The pressure syringe 3 can be filled with contrast agent via the filling tube 12 and the double non-return valve 10. The pressure syringe 4 can be filled with a rinsing agent via the filling tube 13 and the double non-return valve 11. According to the invention, a sensing device 14 is provided which senses the termination of the delivery of the contrast agent by the contrast agent injector 1. The sensing device 14 is preferably provided in the branch 7a of the adapter 7, as indicated in the figure. When necessary, the sensing device 14 can also be provided at a different point.

In order to increase the monitoring reliability, a second sensing device (not shown) may additionally be provided, for example in the branch 7c of the Y-shaped adapter 7. The sensing device 14 is connected to a control device 16 via a line 15. The control device 16 controls, via a control line 17, the delivery of the rinsing fluid by the rinsing injector 2.

In a preferred embodiment, the contrast agent injector 1 has a status display 18, for example a status display lamp. This status display 18 indicates whether the contrast agent injector is ready to operate or whether the injection is terminated or interrupted. The control device 16 is connected via a line 19 to a status display detection device 20 which detects whether the status display lamp 18 is lit. The status display detection device 20 is, for example, an optocoupler or phototransistor which permits the status of the contrast agent injector 1 to be sensed in a galvanically isolated fashion.

In a preferred development, the control device 16 is connected via a line 21 to a contrast agent injection

09590941050

time calculating device 22 which contains a memory device for the contrast agent injection time. A contrast agent injection time can be stored in this memory device for the contrast agent inspection time.

5 The contrast agent injection time calculating device 22 has a timer unit and outputs a signal to the control device 16 via the line 21 when the entire contrast agent injection time has expired.

10 In a further preferred development of the contrast agent injection system according to the invention, the control device 16 is connected via a line 23 to a contrast agent volume calculating device 24. The contrast agent volume calculating device 24 has a
15 memory device for the contrast agent volume, in which the entire contrast agent volume which is to be delivered by the contrast agent injector 1 can be stored. The contrast agent volume calculating device 24 supplies a signal to the control device 16 via the line
20 23 when the total contrast agent volume is reached.

In a further preferred development of the contrast agent injection system according to the invention, the control device 16 is connected via a line 25 to an
25 input device 26 by means of which, for example, the total contrast agent injection time or the total contrast agent volume can be input. The total contrast agent volume which is input is then stored in the memory device of the contrast agent volume calculating
30 device 24. The total contrast agent injection time which is input is stored in the memory device of the contrast agent injection time calculating device 22.

The method of operation of the contrast agent injection
35 system according to the invention will be described below. The sensing device 14 is preferably a fluid flow sensing device which senses the termination of the contrast agent flow in the section 7a. The sensing

Patent 6509960

device 14 then outputs a signal to the control device 16 if no movement of fluid can be detected in the section 7a. A binary flag is then reset ($FS = 0$), which indicates that there is no longer any flow in the section 7a in the control device 16.

The fluid flow sensing device 14 comprises, for example, a light-emitting unit and a light-receiving unit for sensing the light reflection caused by the fluid particles.

The sensing of the light reflection can be performed by an LED and phototransistor located in the same housing. The light emitted by the LED is reflected by the fluid particles in section 7a and received by the phototransistor. If no reflection occurs, it is detected that no fluid particles are present in the section 7a, and the flow is thus terminated.

Alternatively, a photoelectric barrier may also be provided, with the light signal emitted by a light-emitting unit being received more weakly at an associated light-receiving unit as a result of a fluid flowing in the tube, due to reflection from particles.

In a further embodiment, the fluid flow sensing device is composed of a sound-emitting unit and a sound-receiving unit for sensing the sound frequency shifts caused by the moving fluid particles.

In a preferred embodiment, the sensing device 14 is composed of an ultrasonic source which emits ultrasonic waves which are then reflected back by the fluid particles in the patient tube. The reflected ultrasonic waves are sensed by a sound-receiving unit, the received ultrasonic frequency shift being proportional to the velocity of flow in the section 7a.

In further embodiments, the sensing device 14 can, however, also utilize photoelectric, magnetic, inductive or mechanical effects in order to detect the flow of fluid in the section 7a.

5

As long as a flow of contrast agent is sensed in the section 7a, the sensing device 14 outputs a measurement signal, representing the flow, to the control device 16 via the line 15. From the known tube cross section of the section 7a and the sensed flow, the contrast agent volume calculating device 24 calculates the contrast agent volume which is being applied to the patient's body. If the applied contrast agent volume reaches the total contrast agent volume stored in the memory device of the contrast agent volume calculating device 24, the contrast agent volume calculating device 24 emits a signal which indicates that the total contrast agent volume has been reached. A binary volume flag VE in, for example, the control device 16 is reset ($VE = 0$) by means of this signal.

The contrast agent injection time calculating device 22 supplies a time expiry signal to the control device 16 when the total contrast agent injection time is expired. A binary injection time flag ZE is then reset ($ZE = 0$) in the control device 16.

The, if appropriate, additionally provided status display sensing device 20 supplies a sensing signal to the control device 16 via the line 19 if the injection by the contrast agent injector 1 is interrupted and the associated status lamp 18 is lit. A binary status display flag SS is then reset ($SS = 0$) in the control device 16.

35

In one simple embodiment of the contrast agent injection system according to the invention, the control device 16 outputs an injection start signal to

the rinsing agent injector 2 via the control line 17 when the flow flag FS is reset. The rinsing agent injector 2 then injects a rinsing agent, located in the pressure syringe 4, into the right-hand branch 7b of the adapter 7 via the connection 6, and presses the contrast agent still located in the patient tube 9 into the body.

In order to increase safety, in one preferred embodiment of the contrast agent injection system according to the invention the subsequent rinsing process is initiated only when all the binary monitoring flags FS, SS, VE, ZE have been reset. In this preferred embodiment, the control device 16 outputs an injection signal to the rinsing agent injector 2 only when the flow flag FS, if appropriate the status display flag SS, the contrast agent volume flag VE and the injection time flag ZE have been reset (FS = 0, SS = 0, VE = 0, ZE = 0). As a result, safety during the contrast agent injection is significantly increased because errors can also be detected.

The monitoring of a multiphase contrast agent injection in which various injection phases (injection steps), including programmed injection delays or pause times between the injection phases, are provided, can also be carried out by means of the control device 16.

After injection of the first injection phase, the status display flag SS and the flow flag FS are reset (FS = 0; SS = 0), but the total contrast agent volume flag VE and the injection time flag ZE are not reset (VE = 1; ZE = 1). These flags are also reset, and the subsequent injection of the rinsing agent by the rinsing agent injector 2 initiated, only when the entire contrast agent volume has been applied and the total contrast agent injection time has expired.

5069860

The error case, for example, of a bent patient tube 9 can also be detected by the control device 16 by means of the multiplicity of monitoring flags. If the patient tube 9 is unintentionally bent, the flow is interrupted and the flow flag FS is reset. The pressure in the tube system increases until a set pressure limit is reached, as a result of which the flow of contrast agent from the contrast agent injector 1 is automatically reduced or stopped. As a result, the contrast agent injection time is prolonged. After the total contrast agent injection time expires, the injection time flag ZE is reset, although the contrast agent injection has not yet been concluded. However, this does not also lead to an incorrect subsequent injection because in this case the total contrast agent volume has not yet been reached and the contrast agent volume flag VE has not yet been reset (VE = 1). The contrast agent flag VE which has been set prevents the initiation of the subsequent injection.

In an incident or emergency in which the contrast agent injection is stopped by the contrast agent injector 1, the flow flag FS is reset but the other monitoring flags, i.e. the status display flag SS, the injection time flag ZE and the injection volume flag VE, which are all not yet reset, prevent the initiation of the subsequent injection. The control device 16 outputs, via the control line 17, a control signal for initiating the subsequent injection of the rinsing agent by the rinsing agent injector 2 only when all the monitoring flags FS, SS, ZE and VE have been reset.

Provision of various monitoring flags in the contrast agent injection system according to the invention considerably increases safety during the contrast agent injection. Furthermore, various error cases, such as bending of the patient tube or interruption of the

0985059-110301

contrast agent injection in an emergency can also be detected.

In a further embodiment (not shown), the rinsing agent
5 subsequent injector is remote-controlled by the control device 16.

As is apparent from the figure, there is no connection
10 via an electrical connection between the contrast agent injector 1 and the subsequent injection controller 16, or the rinsing agent subsequent injector 2. The contrast agent injection system according to the invention is therefore extremely suitable for retrofitting in an already existing contrast agent
15 injector 1. The contrast agent injector 1 simply has to be plugged onto the connection 5 of the Y-shaped adapter 7.

The refilling of the pressure syringes 3, 4 is
20 preferably carried out as described below. The filling tubes 12, 13 are connected to a reservoir vessel. The pistons of the pressure syringes 3, 4 are then drawn back, as a result of which a partial vacuum arises in the pressure syringe chambers. The double non-return
25 valves 10, 11 clear the path between the reservoir vessel and the pressure syringe, and the fluid is sucked into the pressure syringe from the reservoir vessel. At the same time, the double non-return valve 10, 11 ensures that the connection to the reservoir
30 vessels remains closed during an injection process from the pressure syringes 3, 4 to the patient tube 9. After injection has taken place, the double non-return valve 10, 11 closes owing to the pressure equalization. Because the double non-return valve 10, 11 only permits
35 a movement of injection fluid from the associated pressure syringe 3 or 4 to the patient's body, the body fluid originating from the patient's body is consequently also prevented from being sucked into the

pressure syringe chamber. The same effect can be achieved by using a non-return valve in the patient tube 9.

5 The subsequent injection of the rinsing agent leads to a considerable saving in consumption of contrast agent. If the patient tube has, for example, a volume of approximately 2 ml and the relevant portion of the venous system has a volume of, for example, 10 - 15 ml,
10 the contrast agent saving per patient is approximately 12 ml or 17 ml.

The contrast agent injection system according to the invention detects, by means of the flow sensing device
15 near to the patient, whether too much contrast agent has passed into the patient's body. In addition, additional monitoring flags ensure that cases of errors during the injection of contrast agent are also detected.

20 In one preferred embodiment of the contrast agent injection system according to the invention, the control device 16 is connected via an interface which is already present on the supplementary injector 2, for
25 example for manual triggering.

In a further preferred embodiment, the control device 16 has its own power supply which is independent of the power supply of the injectors 1, 2. This ensures
30 additional safety during the delivery of the contrast agent.

In a further preferred embodiment of the contrast agent injection system according to the invention, the
35 control device 16 controls a display device which indicates the status of the current injection. This display informs the viewer of, for example, how much

0985451910301

contrast agent has already been applied or whether an error case has occurred.

5 In a further preferred embodiment of the invention, the pressure syringe mounting openings 27, 28 of the injectors 1, 2 have different cross sections, said cross sections respectively corresponding to a different mounting opening of the pressure syringes 3, 4. As a result, instances of confusion in which the pressure syringes are inserted into the incorrect injector are prevented. For example, the injector 1 has a round mounting opening for receiving the pressure syringe 3, while the supplementary injector 2 has a hexagonal opening for receiving the pressure syringe 4.

10 The pressure syringe 3 is filled with contrast agent, while the pressure syringes 4 are filled with a rinsing agent. Erroneous confusion of the syringes is thus prevented.

15

09869059-10304

List of reference numerals:

- 1 Contrast agent injector
- 2 Rinsing agent injector
- 5 3 Pressure syringe
- 4 Pressure syringe
- 5 Connection
- 6 Connection
- 7 Adapter
- 10 7a Adapter branch
- 7b Adapter branch
- 7c Adapter branch
- 8 Connection
- 9 Tube
- 15 10 Valve
- 11 Valve
- 12 Filling tube
- 13 Filling tube
- 14 Sensing device
- 20 15 Line
- 16 Control device
- 17 Control line
- 18 Status display
- 19 Line
- 25 20 Status display sensing device
- 21 Line
- 22 Contrast agent injection time calculating device
- 23 Line
- 24 Contrast agent volume calculating device
- 30 25 Line
- 26 Input device
- 27 Mounting opening
- 28 Mounting opening

FOOT " 6506950

Patent Claims

1. Contrast agent injection system for injecting a contrast agent into a body, having at least a first injector (1) for delivering the contrast agent to a tube (9) connected to the body, and having at least a second injector (2) for delivering a rinsing fluid to the tube (9), characterized by a control device (16) which monitors the delivery of the contrast agent through the tube section (7) and automatically controls the delivery of the rinsing fluid by the second injector (2) after the delivery of the contrast agent has been terminated.
2. Contrast agent injection system according to Claim 1, characterized in that the control device (16) is connected to a sensing device (14) which senses the termination of the delivery of the contrast agent.
3. Contrast agent injection system according to Claim 2, characterized in that the sensing device (14) is a fluid flow sensing device which senses the termination of the flow of contrast agent in the tube (9).
4. Contrast agent injection system according to Claim 3, characterized in that the fluid flow sensing device (14) has a light-emitting unit and a light-receiving unit for sensing the light reflection caused by the fluid particles.
5. Contrast agent injection system according to Claim 3, characterized in that the fluid flow sensing device (14) has a sound-emitting unit and a sound-receiving unit for sensing the sound

0985059-1001

frequency shift caused by the moving fluid particles.

- 5 6. Contrast agent injection system according to one of the preceding claims, characterized in that the control device (16) is connected to a contrast agent volume calculating device (24).
- 10 7. Contrast agent injection system according to Claim 6, characterized in that the contrast agent volume calculating device (24) has a contrast agent volume memory device in which the contrast agent volume located in the first injector (1) is stored.
- 15 8. Contrast agent injection system according to one of the preceding claims, characterized in that the first injector (1) has a status display (18).
- 20 9. Contrast agent injection system according to one of the preceding claims, characterized in that the control device (16) is connected to a detection device (20) for detecting a status display signal emitted by the status display (18) of the first injector (1).
- 25 10. Contrast agent injection system according to one of the preceding claims, characterized in that the control device (16) is connected to a contrast agent injection time calculating device (22).
- 30 11. Contrast agent injection system according to Claim 10, characterized in that the contrast agent injection time calculating device (22) has a contrast agent injection time memory device in which the contrast agent injection time is stored.
- 35

FOOTNOTES

12. Contrast agent injection system according to one of the preceding claims, characterized in that the control device (16) is connected to an input device (26) for inputting the contrast agent volume and the contrast agent injection time.
13. Contrast agent injection system according to one of the preceding claims, characterized in that the first injector (1) and the second injector (2) are connected via an adapter (7) to a tube (9) which is connected to the body.
14. Contrast agent injection system according to Claim 13, characterized in that valves (10, 11) are provided for filling the injectors (1, 2).
15. Contrast agent injection system according to Claim 14, characterized in that the valves (10, 11) can be controlled via the control device (16).
16. Contrast agent injection system according to one of the preceding claims, characterized in that the rinsing fluid is sodium chloride.
17. Contrast agent injection system according to one of the preceding claims, characterized in that the injectors (1, 2) are single-piston or multipiston injectors.
18. Contrast agent injection system according to one of the preceding claims, characterized in that interchangeable pressure syringes (3, 4) can be held by the injectors (1, 2) in mounting openings (27, 28).
19. Contrast agent injection system according to Claim 18, characterized in that the mounting openings (27, 28) have different mounting openings

0969099-10501

corresponding to the associated pressure syringes (3, 4).

- 5 20. Contrast agent injection system according to one of the preceding claims, characterized in that the control device (16) has a multiplicity of internal monitoring flags (FS, SS, VE, ZE) for monitoring the delivery of contrast agent.
- 10 21. Contrast agent injection system according to Claim 20, characterized in that the control device (16) controls the second injector (2) in order to deliver the rinsing agent when all the monitoring flags (FS, SS, VE, ZE) indicate the termination of
- 15 the delivery of contrast agent.

105077 6306960

Abstract

Contrast agent injection system for injecting a contrast agent into a body, having at least a first injector 1 for delivering the contrast agent to a tube section 7 which is connected to the body, and at least a second injector 2 for delivering a rinsing fluid to the tube section 7, a control device 16 monitoring the delivery of the contrast agent through the tube section 7 and automatically controlling the delivery of the rinsing fluid by the second injector 2 after the delivery of the contrast agent has been terminated.

(Figure)

TECH 65069860

1/1

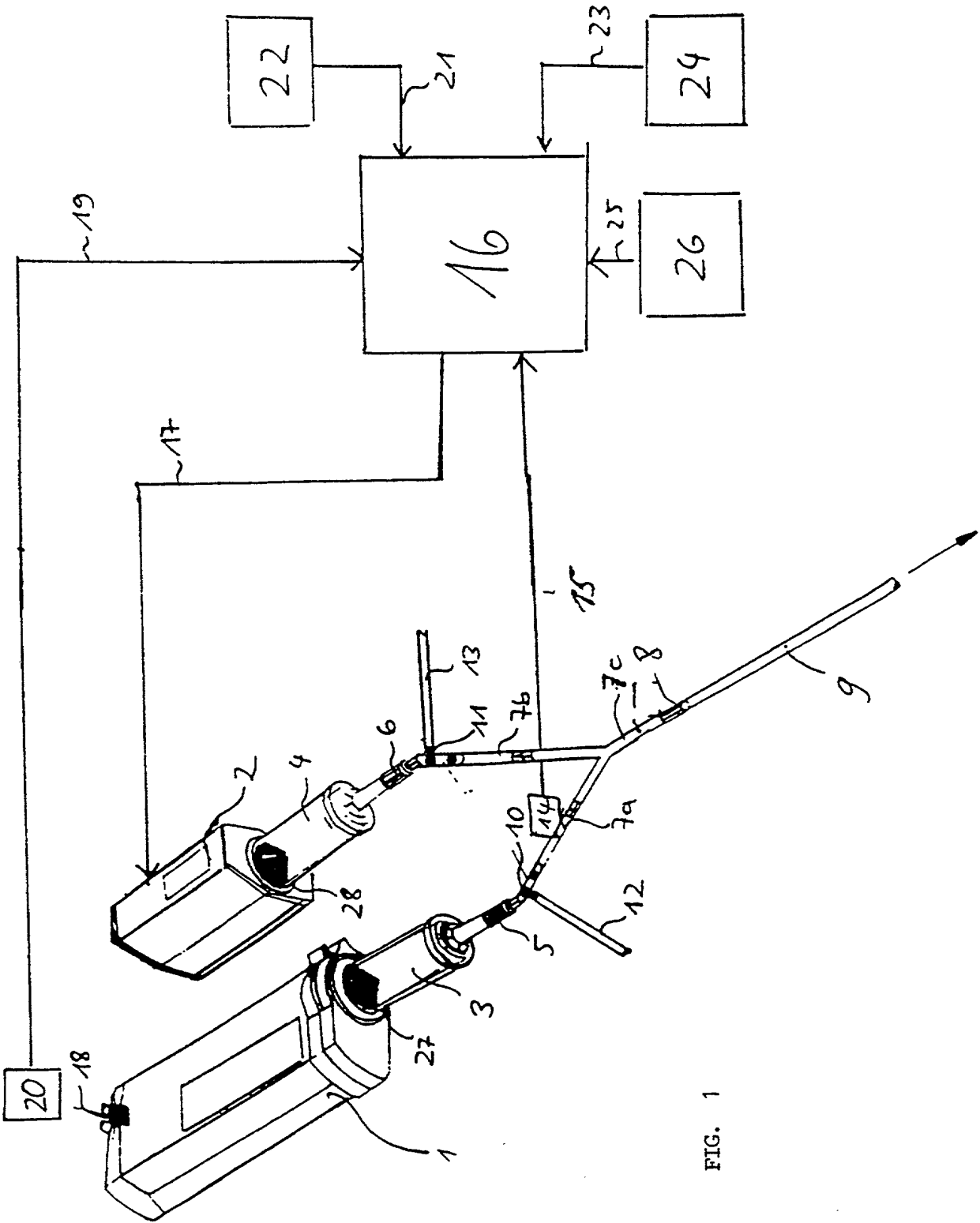

FIG. 1

FOOTPRINT 65069860

DECLARATION AND POWER OF ATTORNEY

As a below named inventor, I hereby declare that my residence, mailing address and citizenship are as stated below next to my name: that I verily believe I am the original, first and sole inventor (if only one name is listed below) or an original, first and joint inventor (if plural names are listed below) of the subject matter claimed and for which a patent is sought in the application entitled:

SYSTEM FOR INJECTING A CONTRAST MEDIUM

which application is:

the attached application
(for original application)

Application No. UNKNOWN
(Confirmation No. UNKNOWN) filed June 25, 2001
, and amended on
(for declaration not accompanying application)

that I have reviewed and understand the contents of the specification of the above-identified application, including the claims, as amended by any amendment referred to above; that I acknowledge my duty to disclose information of which I am aware and which is material to the patentability of this application as defined in 37 C.F.R. 1.56, that I hereby claim priority benefits under Title 35, United States Code §119(a)-(d) or §365(b) of any foreign application(s) for patent or inventor's certificate, §119(e) of any United States provisional application(s), or §365(a) of any PCT International application which designated at least one country other than the United States of America, listed below and have also identified below any foreign application for patent or inventor's certificate or of any PCT International application having a filing date before that of the application on which priority is claimed:

Application Number	Country	Filing Date	Priority Claimed	
			Yes	No
19859811.4	DE	December 23, 1998	<input checked="" type="checkbox"/>	<input type="checkbox"/>

I hereby claim the benefit under 35 United States Code §120 of any United States application(s), or §365(c) of any PCT International application designating the United States, listed below and, insofar as the subject matter of each of the claims of this application is not disclosed in a listed prior United States or PCT International application in the manner provided by the first paragraph of Title 35, United States Code, §112, I acknowledge my duty to disclose any information material to the patentability of this application as defined in 37 C.F.R. 1.56 which occurred between the filing date of the prior application and the national or PCT international filing date of this application:

Application No.	Filing Date	Status
-----------------	-------------	--------

I hereby appoint John H. Mion, Reg. No. 18,879; Thomas J. Macpeak, Reg. No. 19,292; Robert J. Seas, Jr., Reg. No. 21,092; Darryl Mexic, Reg. No. 23,063; Robert V. Sloan, Reg. No. 22,775; Peter D. Olexy, Reg. No. 24,513; J. Frank Osha, Reg. No. 24,625; Waddell A. Biggart, Reg. No. 24,861; Louis Gubinsky, Reg. No. 24,835; Neil B. Siegel, Reg. No. 25,200; David J. Cushing, Reg. No. 28,703; John R. Inge, Reg. No. 26,916; Joseph J. Ruch, Jr., Reg. No. 26,577; Sheldon I. Landsman, Reg. No. 25,430; Richard C. Turner, Reg. No. 29,710; Howard L. Bernstein, Reg. No. 25,665; Alan J. Kasper, Reg. No. 25,426; Kenneth J. Burchfiel, Reg. No. 31,333; Gordon Kit, Reg. No. 30,764; Susan J. Mack, Reg. No. 30,951; Frank L. Bernstein, Reg. No. 31,484; Mark Boland, Reg. No. 32,197; William H. Mandir, Reg. No. 32,156; Brian W. Hannon, Reg. No. 32,778; Abraham J. Rosner, Reg. No. 33,276; Bruce E. Kramer, Reg. No. 33,725; Paul F. Neils, Reg. No. 33,102; Brett S. Sylvester, Reg. No. 32,765; Robert M. Masters, Reg. No. 35,603; George F. Lehnigk, Reg. No. 36,359; John T. Callahan, Reg. No. 32,607; Steven M. Gruskin, Reg. No. 36,818; Peter A. McKenna, Reg. No. 38,551 and Edward F. Kenchan, Reg. No. 28,962, my attorneys to prosecute this application and to transact all business in the Patent and Trademark Office connected therewith, and request that all correspondence about the application be addressed to **SUGHRUE, MION, ZINN, MACPEAK & SEAS, PLLC**, 2100 Pennsylvania Avenue, N.W., Washington, D.C. 20037-3213.

I hereby declare that all statements made herein of my own knowledge are true and that all statements made on information and belief are believed to be true; and further that these statements were made with the knowledge that willful false statements and the like so made are punishable by fine or imprisonment, or both, under Section 1001 of Title 18 of the United States Code and that such willful false statements may jeopardize the validity of the application or any patent issuing thereon.

Date	_____	First Inventor	<u>Ralph</u>
Residence	<u>Untere Schlosstr. 21</u>	Signature	<u>Berke</u>
	<u>D-86441</u>	First Name	Middle Initial
	<u>Zusmarshausen,</u>	Last Name	
	<u>Deutschland</u>		
City	<u>State/Country</u>		
Mailing Address:	<u>Untere Schlosstr. 21</u>		
	<u>D-86441 Zusmarshausen,</u>		
	<u>Deutschland</u>		
Citizenship	_____		